

KPZ-Waagen Stainless steel scale Program

German design and own EU production guarantees high quality.

Stainless steel Material : DIN 1.4301 / 1.4541 / 1.4404

IP 67/68 + IP 69K



KPZ 1N/
IP67/68 / IP 69K



KPZ 717 N
IP67/68 / IP 69K



KPZ 2E06N /
váha IP67/68 / IP 69K

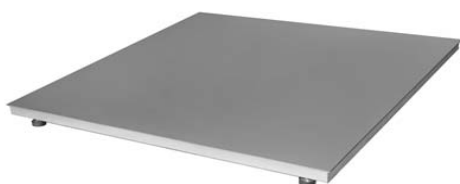

KPZ 2N / IP67/68 / IP 69K



KPZ 2N /
IP67/68 / IP 69K



KPZ 2NE065 / IP67/68 / IP 69K

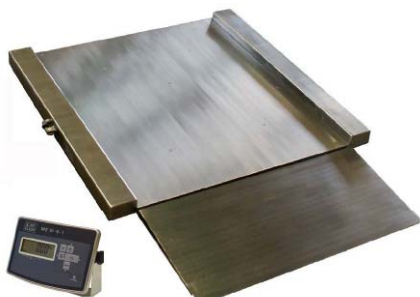

KPZ 2DN / IP67/68 / IP 69K



KPZ 2DN / IP67/68 / IP 69K
Váživost: až 3.000kg



KPZ 2E-07-2N M
Wall folding scale
Stainless steel, DIN 1.4301 /
IP67/68
and IP 69K



KPZ 52E91 



KPZ 5E92 



KPZ 51E-45K, IP 69 K



KPZ 54E-* 

KPZ 71-7N / hand pallet truck with integrated scale
stainless steel DIN 1.4301 / IP67/68+ IP 69K

Capacity 2.200 kg | Division : 100g , 200 g, 500g | accuracy: **0,02 %**

EU-approval class **M** Klasse III

USA Version Page 4

weighing capacity up to **2.200 kg**

25 mm LCD – digits

backlight

100 % tare

easy readable



Option
KPZ 51E-9-2,
with build-in printer



Option
feet drum brake



Better quality !!! KPZ applies only EU approved components
Weighning Economy plus ! = Saved working hours

Solid and stable platform scales series KPZ 71-7N. German design and own EU production guarantees high quality. Designed as floor scales, for **food and Chemical industrial weighing. High accuracy. Maintenance-free durable **Stainless steel (DIN 1.4301 / IP67/68 / 69K)** construction. High quality polishing standard.**

Construction: Robust, maintenance-free, welded steel construction, heavy duty design for food industrial use, **Stainless steel** weighing platform, Maintenance-free durable **Stainless steel (DIN 1.4301 / IP67/68 /**

Load cells: Robust, **stainless steel load cell**, IP68, OIML, with a high overload capacity.

Installation: Adjustable leveling feet, designed for permanent or portable installations, 5m cable to connect digital indicator.

Options: Custom sizes and capacities

Standard indicator: KPZ 52E91

For approved applications: KPZ 52E91

Options for indicators:



Multi range,
RS 232 serial interface,
Various printers connection,
Radio data transfer,
WLAN, etc..
Internal battery

Approvals: OIML class III , CE conform

Power Supply : 230 V mains, Power cord

Construction: complete stainless steel version of KPZ 71-7. High quality flat iron construction just constructed for weighing technic. **steering wheels: Nylon (Ø 200mm) fork wheels: Tandem Nylon. weighingsystem: 4 high grad, stainless steel loadcells, Type KPZ 502E-3, IP68, EU approval certification class III, accuracy: 0,02%, power supply: Accu, charger incl. Certification:** EC approval possibility class III, Declaration of conformity, approved version.

hand pallet weigher KPZ 71-7N stainless steel [Material 1.4301](#)

Typ	Fork Diam. mm	Capacity kg	Div.g	Approval	Indicator:	PLN/pc	Article – No.
KPZ 71-7N,	560x1150	2200	500	No	KPZ 52E91/IP67	On Request	717N00002200
KPZ 71-7NM,	560x1150	1500/2200	200/500	No	KPZ 52E91/IP67	On Request	717NM0002200
KPZ 71-7N,	560x1150	1500	200	No	KPZ 52E91/IP67	On Request	717NM0001500
KPZ 71E-7N	680x1150	2.200 kg	500 g	No	KPZ 52E91/IP67	On Request	717N07002200
KPZ 71E-7N,	560x1150	600	200g	YES 	KPZ 52E91/IP67	On Request	717N0000060E
KPZ 71E-7NM,	560x1150	1500	500g	YES 	KPZ 52E91/IP67	On Request	717NM000150E
KPZ 71E-7N,	560x1150	1.500/2200	500/1000g	YES 	KPZ 52E91/IP67	On Request	717NM000220E
KPZ 71E-7N,	560x1150	2200	1000g	YES 	KPZ 52E91/IP67	On Request	717N0000220E
KPZ 71E-7N	680x1150	2.200 kg	1000 g	YES 	KPZ 52E91/IP67	On Request	717N0700220E

Option : Fork high 75 mm

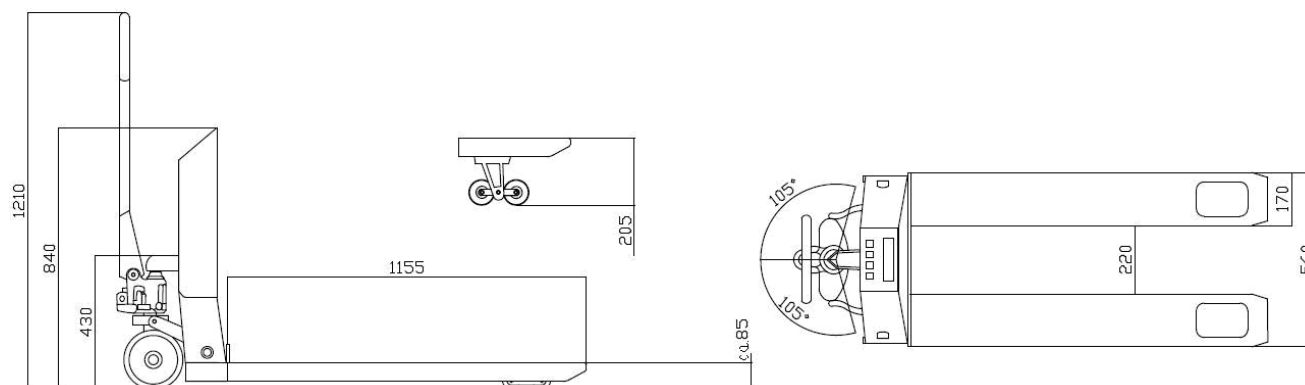

own weight approx. 150 kg.

**Stainless steel DIN 1.4301 / 1.4541 / 1.4404
and IP 67/68 + IP 69K version possible**

Options? Ask us, we do almost everything possible for you

KPZ 71N / Palletweiger

Pallet Truck with integrated Scale

Solid Pallet weiger for industrial use

Stainless steel DIN 1.4301(NEMA 6)



Palletweiger type KPZ 71-7N

Weighing capacity : 4500 lb, Division: 1 lb



Construction : KPZ 71-7N palletweiger very solid and stable stainless steel construction, Stainless steel DIN 1.403, , for industrial use, long exploitation period, total weight 150 kg. Steering wheels: polyamide tandem rollers, battery and adapter.

Load cells: 4 high quality stainless steel DMS load cells KPZ 502E-2, IP 68, OIML class III, **Indicator:** KPZ 51E9-1,(possibility to deliver with different model), solid stainless steel housing.

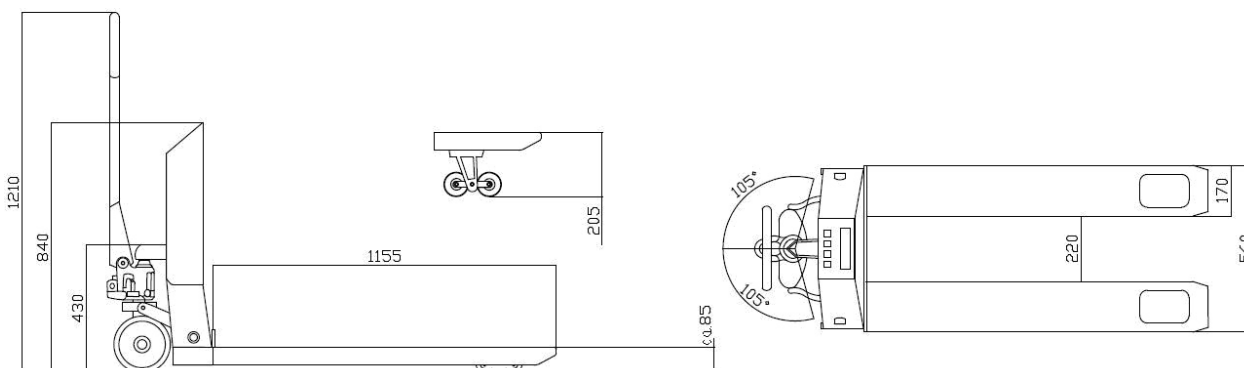
Certificate: EU type approved class III.



Effortless pallet Entry/Exit rollers to make it easier to push and pull by operator. Lubrication grease nipples on allmovable parts for easy maintenance. Ergonomic Large Rubber handle with three control lever. Easy to maneuver with 210 degrees turning radius. Special lowering valve to control the rate of descent and over load by-pass valve to make the truck durable.

Model	Capacity	division	Size (in)	Fork(mm)	Approval possible	indicator	Price \$	Article-Nr.
KPZ 71-7N	2500 lb	0,2 lb	47 x 27"	1150 x 560	No	KPZ 52-91		717N00000250L
KPZ 71-7N	2500 lb	0,2 lb	47 x 27"	1150 x 680	No	KPZ 52-91		717N00000250L
KPZ 71-7N	2500 lb	0,5 lb	47 x 27"	1150 x 680	YES 	KPZ 52-91		717NE0000250L
KPZ 71-7NH	4500 lb	0,2 lb	47 x 27"	1150 x 680	No	KPZ 52-91		717NH0000450L
KPZ 71-7NH	4500 lb	1,0 lb	47 x 27"	1150 x 680	YES 	KPZ 52-91		717NE0000450L
KPZ 71-7NM	2500/4500 lb	0,2/0,5 lb	47 x 27"	1150 x 680	No	KPZ 52-91		717NM0000450L



KPZ 1-*

KPZ 2-*

KPZ 2-*



KPZ 71-*



KPZ 72-*



KPZ 73-*



KPZ 74-*



Weighing forks Forklift truck scale



Electronic - Hydraulic version



Scale for Coil's



Stainless steel, IP 67/68/ 69K



KPZ-Waagen Indicator



KPZ 52E8



KPZ 52E8-1



KPZ 56E4



KPZ 54-1*



KPZ 52-18



KPZ 52E9-1



KPZ 52E9-2