









KPZ 71-* / Mobil scale

 		
 	 	 
		
 	 	
	 	
	 	 Scale for Coil's 
		

KPZ 71-8 / Palletweigher

(pallet truck with scale)

Standard capacity: 2.200 kg Div. 200g / accuracy 0,02% on the weighing

Weights&measures | powder coating | good value for money | solid

As Option possible : OIML Class   SOLAS konform







USA Version Page 5



Option : Printer KPZ 71-8

- Indicator in steel housing
- Easy to operate
- Industrial quality
- Tandem rollers
- 6 Digit 25 mm high LCD Display
- 100% tare / multi tare
- Switch net and gross
- Good read out
- Option:
EC approval possibility: Class 
Printer

Better quality !!! KPZ applies only EU approved components
Weighning Economy plus ! = Saved working hours

Typ	Fork Diam. mm	Capacity	Div.	Approval	Indicator:	PLN/pc	Article – No.
KPZ 718SJ	560x1150	2200 kg	100 g	Ne	KPZ 5172	On request	718SJ00002200
KPZ 718SJ	560x1150	2200 kg	200 g	Ne	KPZ 5172	On request	718SJ00002200
KPZ 718SMH	560x1150	1100/2200 kg	100/200 g	Ne	KPZ 5172	On request	718SMH002200
KPZ 718S	560x1150	2500 kg	1000 g	Ne	KPZ 5172	On request	718S000002500
KPZ 718S	560x1150	3000 kg	1000 g	Ne	KPZ 5172	On request	718S000003000
KPZ 718SL	680x1150	2.200 kg	500 g	No	KPZ 5172	On request	718S00202200L
KPZ 718SE	560x1150	2200 kg	1000 g	Ano 	KPZ 51E7	On request	718S0000220E
KPZ 718SE	560x1150	1500 kg	500 g	Ano 	KPZ 51E7	On request	718S0000150E
KPZ 718SE	560x1150	600 kg	200 g	Ano 	KPZ 51E7	On request	718S0000060E
KPZ 718SME	560x1150	1100/2200 kg	500g/1000 g	Ano 	KPZ 51E7	On request	718SM000220E
KPZ 718SE	560x1150	2500 kg	1000 g	Ano 	KPZ 51E7	On request	718S0000250E
KPZ 718SE	560x1150	3000 kg	1000 g	Ano 	KPZ 51E7	On request	718S0000300E
KPZ 718SEL	680x1150	1100/2200 kg	500g/1000 g	Ano 	KPZ 51E7	On request	718S0020220EL

Option : Fork high 75 mm

German design and own EU production guarantees high quality.
Mobile weighing Saved working time / simply use, take the Palletweigher, drive directly under the pallet or load, pump up, weighing and drive the load to the point of use.

Construction: high quality, for industrial use, solid and stable steel construction. Powder painted yellow colour (RAL 1003), welded drawbar, robust forks. Safe, proven in industrial use hydraulics. Large rubber steering wheels Ø 200mm and polyurethan-tandem rolls. Wheels suspension guarantees stability and movement fluency, built in lubrication grease nipples guarantee long operating life of all movable construction parts. Indicator described below is built in a robust steel housing on height comfortable for operator.

Certification: non approved version and EU type approved version for retail use, CE – conform.

Standartní indikátor: non approval version:

KPZ 52-72
 (Details and options for Indicator see data sheet)

Standardní indikátor approval version:

KPZ 52E-8 (Details and options for Indicator see data sheet)

Power supply : 6V battery, operating time up to 60 hours. Charger included.

Load cells:

High quality load cells KPZ 502E-3, IP 68, OIML C3; EC approval possible

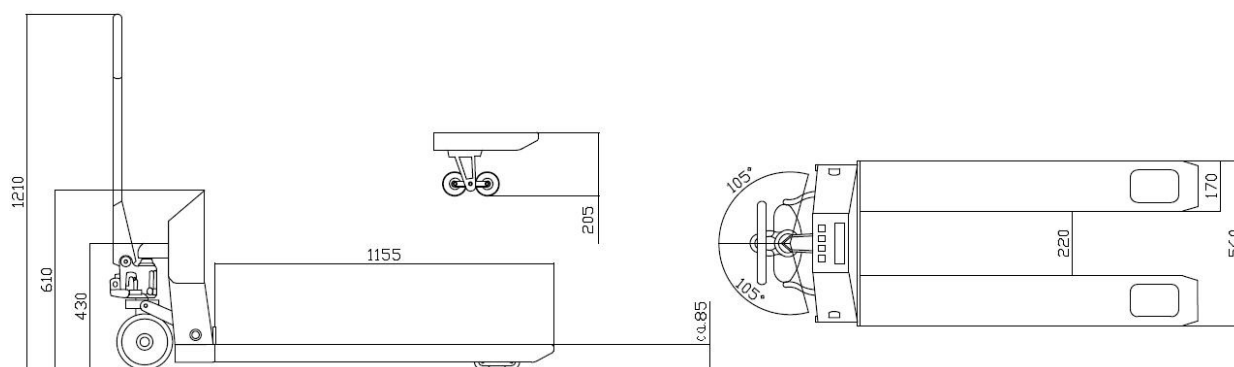

Options? Ask us, we do almost everything possible for you

Options/ accessories / extra charge	PLN/pc	Article-Nr
<i>Indicators: Options (extra cost)</i>		
Indicator KPZ 52E-7/1, with pre tare and easy counting	On request	171430000000
Indicator KPZ 52E-9-1, Stainles steel housing (IP 67) easy counting	On request	171519100000
Indicator KPZ 51E-9-2, Stainles steel housing (IP 67), High/OK/LOW, 10 Memory	On request	171519200000
Indicator KPZ 56E-4, professionelle counting, addition, Tare input by hand, 10 Memory	On request	171324000000
Indicator KPZ 58-2 reference piece counting scale, 2 t/500 g, 1 t/200 g, 0,5 t/100 g	On request	171330000000
Printers: Options (extra cost) + costs for output RS 232		
Roller printer FAVORIT Plus, for KPZ 51(E)-*	On request	171023000000
Label printer and codeprinter type DR 2 for KPZ 56E-4	On request	171334000000
Print design for DR 2 on request	On request	204333100000
serial interface / Setpoints: Options / extra costs		
Serial interface RS232 C for KPZ 52E-7	On request	171307000000
Serial interface RS232 C for KPZ 52E-9-1	On request	171307100000
Serial interface RS232 C for KPZ 51E-9-2	On request	171307200000
Serial interface RS 232 C for KPZ 56E-4 incl. PT and addition	On request	171030800000
Serial interface RS 232 C for KPZ 56E-4 incl. RTC, without PT, without addition	On request	171030700000
Setpoints, 3 pcs for KPZ 52(E)-7 (more- OK - less)	On request	171131000000
Software "KPZ Smart Scale" STANDARD (incl. RS232 serial interface)	On request	5S0001000000
Software "KPZ Smart Scale" PROFESSIONAL (incl. RS232 serial interface)	On request	5S0005000000
Software "KPZ Smart Scale" PREMIUM (incl. RS232 serial interface)	On request	5S0010000000
Wi-Fi Datatransfer	On request	120005000000

Options/ accessories / extra charge	PLN/pc	Article-Nr
Construction options		
Hand break	On request	171701000000
Turning housing for indicator KPZ 51E-7, range 320°	On request	17151E704400
Quicklifting for KPZ 71-7	On request	171700313000
Load wheel / Nylon	On request	171415000000
Load wheel / Nylon, tandem	On request	171415100000
Steering wheel / Nylon	On request	171417000000
Steering wheel / Polyurethane	On request	171417100000
Other forks width, 480 mm to 680 mm	On request	171311000000
Other forks length, 850 mm to 1550 mm	On request	171310000000
Other forks length, 1600 mm to 1800 mm	On request	171320000000
Other forks length, 2000 mm and longer	On request	171502050000
Galvanized version, nickel-plated load cells	On request	171412000000
Forks cover plate, stainless steel	On request	171413200000
1 set of nickel- plated load cells KPZ 71-*	On request	171413100000
Exchangable battery	On request	171704000000



<i>weights & measures certification (extra charge)</i>		
KPZ Factory first certification from 550 kg up to 3.000 kg	On request	300PL0003000

Packing dimension	
Type	Packing dimension
KPZ 71-7	153 x 65 x 125 cm, ca. 155 kg

Other capacity, division, option and dimension on request.
 Calibration protocol as an option. Price on request.

Options? Ask us, we do almost everything possible for you

USA Version

Model	Capacity	division	Size (in)	Fork(mm)	Approval possible	indicator	Price \$	Article-No.
KPZ 71-8S	2500 lb	0.2 lb	47 x 27"	1150 x 560mm	No	KPZ 52-7-2		717S00000250L
KPZ 71-8S	2500 lb	0.2 lb	47 x 27"	1150 x 680mm	No	KPZ 52-7-2		717S00000250L
KPZ 71-8S	2500 lb	0.5 lb	47 x 27"	1150 x 680mm	YES 	KPZ 52E-7		717SE0000250L
KPZ 71-8SH	5000 lb	0.2 lb	47 x 27"	1150 x 680mm	No	KPZ 52-7-2		717SH0000500L
KPZ 71-8SH	5000 lb	1.0 lb	47 x 27"	1150 x 680mm	YES 	KPZ 52E-7		717SE0000500L
KPZ 71-8M	2500/5000 lb	0.2/0.5 lb	47 x 27"	1150 x 680mm	No	KPZ 52-7-2		717SM0000500L
KPZ 71-8	5500 lb	2 lb	47 x 27"	1150 x 680mm	YES 	KPZ 52E-7		717SE0000550L
KPZ 71-8	6500 lb	2 lb	47 x 27"	1150 x 680mm	YES 	KPZ 52E-7		717SE0000650L

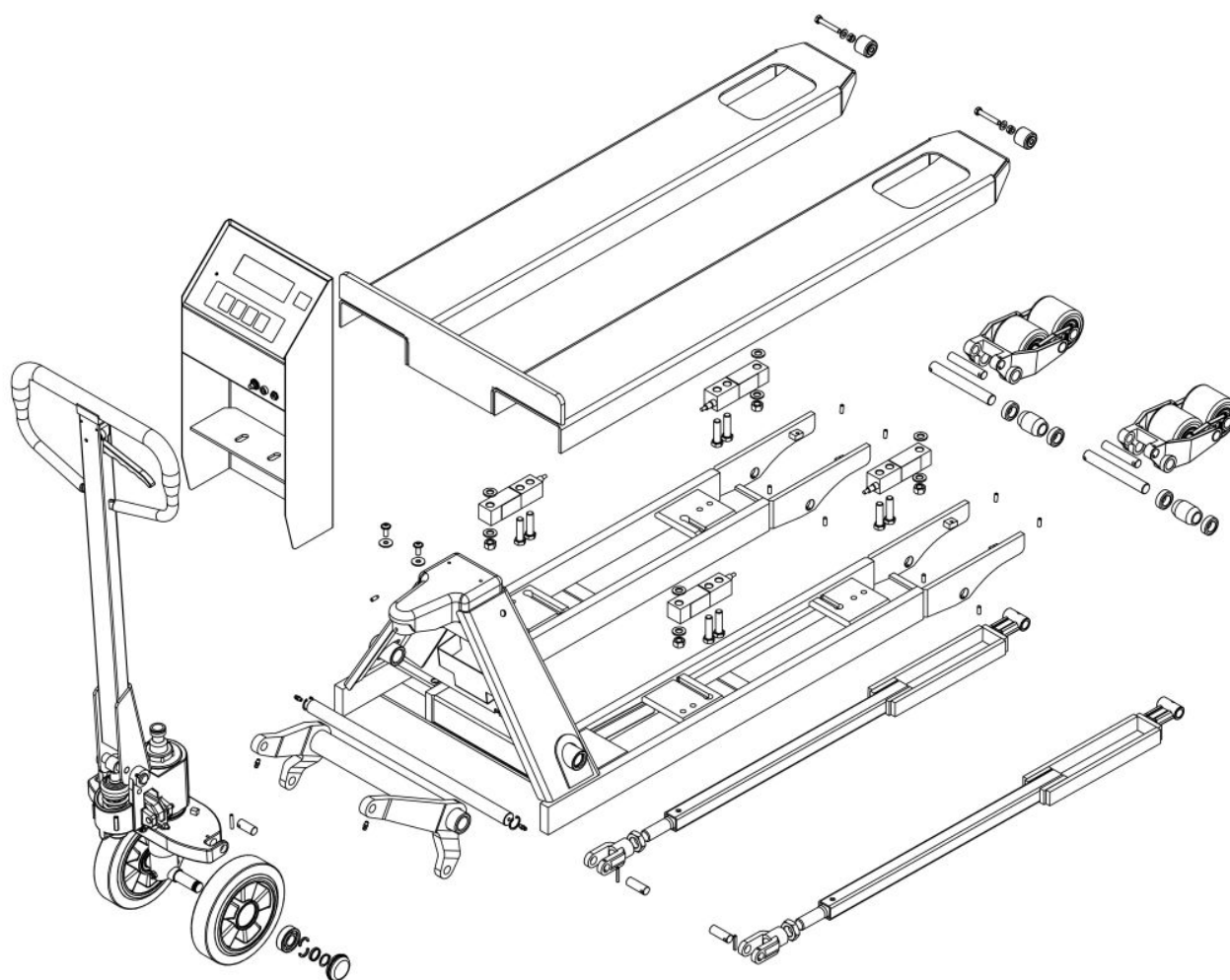

Options? Ask us, we do almost everything possible for you

Other capacity, division, option and dimension on request.

KPZ Indicators

 <p>KPZ 52E-7</p> <p>Klasse III M</p>	 <p>KPZ 52E-7/1</p> <p>Klasse III M</p>	 <p>KPZ 56E-4</p> <p>Klasse III M</p>
 <p>KPZ 52E-9-1</p> <p>Klasse III M</p>	 <p>KPZ 51E-9-2</p> <p>Klasse III M</p>	 <p>KPZ 51E11 - 13</p>
 <p>KPZ 52E-7</p> <p>Klasse III M</p>	 <p>KPZ 52-19</p>	 <p>Big display/second display</p>
 <p>KPZ 54E-*</p> <p>Klasse III M</p>	 <p>KPZ 54E-*</p> <p>Klasse III M</p>	

We reserve the right to make technical modifications and price changes without prior notification

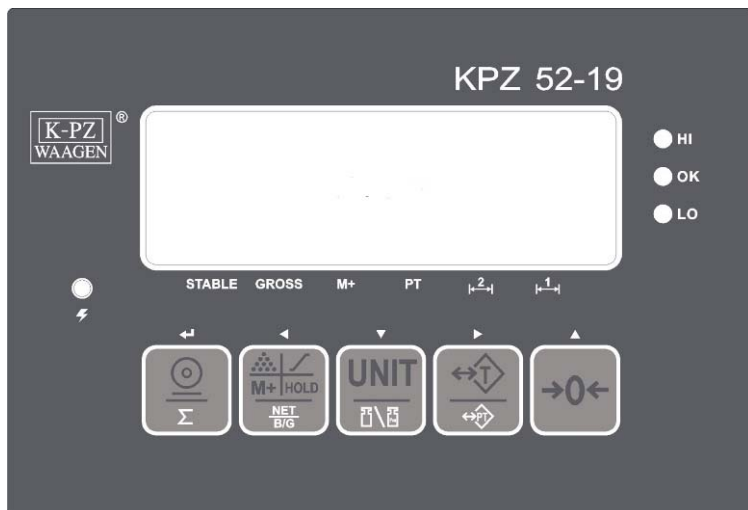

Description : KPZ 52-19 / 52-72









Robust external case made from ABS including a water-proof front keypad with large function keys. 6-digit, 30 mm high LCD – Display with blue back-light function providing a clear and easily readable weight indication. Operating temperature – 10 to + 40 °C. 230 Volt-operation. Battery operation possible.

Function : automatic and manual Zero setting. Tare setting up to 100 %, pretare function, switch Net and gross weight repeatedly. Optional RS 232 Data output and addition sum printing, minus indication, HIGH-OK-LOW function, totalizing function, automatic selftest, Error message on display.

LED indication for : Zero, Tare weight, stable, LOW Bat, HI LOW OK .

Options: RS 232 output, data output, Roller printer,

Description : KPZ 52-19

Key	Function	Hold for 1 sec.
	Printout / data output (Option)	Communication settings
	Totalizing	
	Modus selection / Function	/
	Switching between net and gross weight (net mode)	
UNIT	switching units	
	Switch between weight / unit weight (piece counting mode)	1. Backlight 2. Switch on zero setting 3. Gravitation value
	Tare	
	Pretare	
	Zero	battery voltage

Description KPZ 52(E) - 7

Robust external case made from ABS incorporating a water-proof front keypad with large function keys. 6- digit, 26 mm high LCD – Display with back-light function providing a clear and easily readable weight indication. Operating temperature – 10 to + 40 °C. 230 Volt-operation.

Function : automatic and manual Zero setting. Tare setting up to 100 %, switch Net and gross weight repeatedly. Optional RS 232 Data output and addition sum printing, minus indication, LCD back-light (3 settings), audible/visible alarm/check HIGH-OK-LOW (That means two available value of weight), automatic selftest, Error message on display.



LED indication for : Zero, Tare weight, stabile, LOW Bat, power, addition memory.

Options: Configurable RS 232 output, data output (different formats), Roller printer, label printer, set point (High-OK-Low),



Multirange division : See technical data of the scale.

OIML Class  

Key	Description
ON/OFF	This key is installed on the ABS housing. This key is used to switch the indicator ON or OFF. When activated the display shows the →0← signal is on.
→0←	If the LCD Display is not indicating 0.00 , press this key to re-zero the scale. The display indicates that the ZERO signal is now on. The unit can zero $\pm 2\%$ of the max. capacity. Using this switch do not change the range of maximal capacity.
↔T	This key is used to carry out tare and zero settings, when an existing weight is on the scale. If a TARE weight is stored, the Tare Signal will indicate over Net . As soon as you remove the TARE weight re-set to ZERO by the user of the scale, the display shows the weight with a minus symbol in front on the LCD display. The maximum weighing range is reduced for the tare value. Tare capability is 100% of the scale capacity, and can be used repeatedly. Multiple tare is possible. Negative weight values can be moved to 0.00 .
NET GROSS	This key is used to switch between net and gross weight repeatedly. The display indicate Net or τ GROSS. This NET GROSS key can be used only when the scale is in the tare mode. By showing the Gross value (τ GROSS) the other keys are closed.
	If a printer interface is installed, this key will print out (printer version) or transfer the weight data being displayed . The weight value is stored in the data logger. The display indicate τ M+ .To print the grand total of all printed weights the weight must be removed. The display shows →0← . Then press the  key twice the total sum of the weighing results will be printed .



Tare setting by key,
Piece counting by reference numbers
Zero setting,
Alarm / check control setting,
back light LCD-Indicator,
Addition sum memory,
Multi range division,

OIML trade approved Class  







Description KPZ 52(E) – 8/1

Robust external case made from ABS incorporating a water-proof front keypad with large function keys. 6- digit, 26 mm high LCD – Display with back-light function providing a clear and easily readable weight indication. Operating temperature – 10 to + 40°C. 230 Volt-operation.

Function : automatic and manual Zero setting. Tare setting up to 100 %, switch Net and gross weight repeatedly. Optional RS 232 Data output and addition sum printing, minus indication, LCD back-light (3 settings), audible/visible alarm/check HIGH-OK-LOW (That means two available value of weight), automatic self test, Piece counting by reference numbers. Error message on display.

LED indication for : Zero, Tare weight, stable, LOW Bat, power, addition memory.

Options: Configurable RS 232 output, data output (different formats), Roller printer, label printer, output for set point (High-OK-Low),

Key	Description
ON/OFF	This key is installed on the ABS housing. This key is used to switch the indicator ON or OFF. When activated the display shows the →0← signal is on.
	Use this key to set up the alarm/check control value.
M+	Use this key to add the piece or weight total into memory
	Use this key to switch over the unit of measurement required.
	Use this key to select the backlight function (3 options).
	Use this key to increase the value shown at the display.
	Use this key to confirm entered quantity.
PCS	Use this key to call up the piece counting reference (10, 20, 50, 100)
→0←	Use this key to Zero the scale
↔T↔	Use this key to carry out TARE and ZERO.
←R←	Use this key to call up the value. (e.g. addition total, pre-tare, peak value)
CE	Use this key to clear the memory value (e.g. addition total, pre-tare, peak value)
	With this key function you transfer the data to RS 232 output. (different formats)
	With this key function you select Option for RS 232 is confirmed.

We reserve the right to make technical modifications and price changes without prior notification

Description KPZ 56E-4



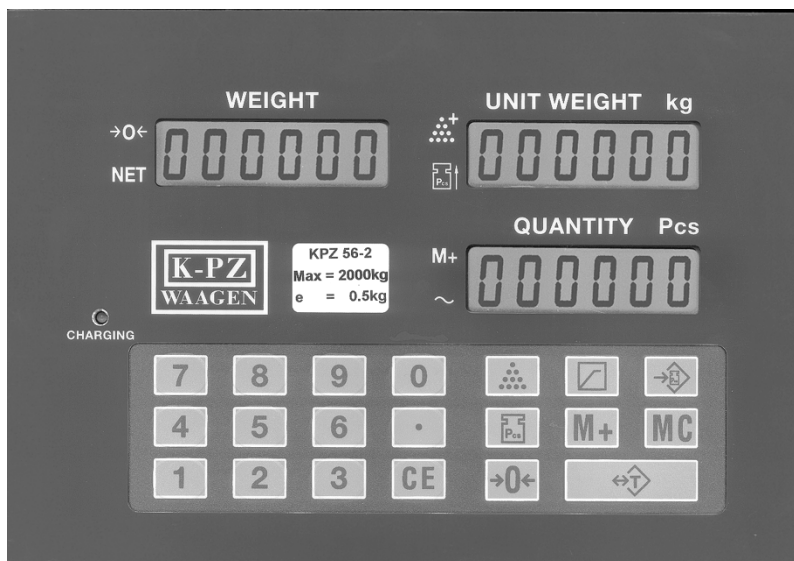

This high-quality Parts Counting Indicator can be used in all types of uncertified and for trade weighing applications. Due to the high external resolution and the 20x expanded internal resolution, the unit is ideally suitable for both small and large item component counting. The expanded internal resolution of the indicator provides clear signal stability and repeatability. The 3 window highly visible LCD-Display provides the operator with clear data information. Additionally, with the robust construction of a steel housing, built-in rechargeable battery, and the simple to operate dust and waterproof front keypad, makes this part counting indicator a valuable tool for all industrial weighing & counting applications.



Optimal unit weight for the piece count: 1/5 of the scale division.

OIML trade approved Class  **M**

Description of Keypad

0 to 9 and .	Use to enter piece weight, total quantity or Tare value.
CE:	Deletes all value entered via the keypad.
→0←	1) Use this key to Zero the scale 2) Use this key by pressing twice to enter backlight options (see Backlight Function)
	Use this key to Tare the scale
	Use this key to confirm entered quantity.
	Use this key to confirm entered piece weight.
	Use this key to pre-set upper count limit, when the value is achieved an audible signal will be emitted.
	Use this key to save a piece weight in memory.
M+	Count accumulation key.
MC	Deletes all accumulation count in memory.

Standard features :Indicator: Display indication 1/30.000, internal divisions 1/600.000. Built-in calibration routine. Automatic & manual zero setting. 100% Tare. Piece Counting. The tare value and the piece weight can be weighed or entered via the front keyboard. The indicator has a 10 piece weight memory. 3 window LCD display with back-lighting option showing weight, quantity and individual piece weight. Counting accumulation. Audible peak alarm for Multi counting applications. Symbol indication shown at display for : Power re-charging control, LO-BAT. Zero, Tare, Stable, Memory, Piece number, Piece weight.

Options :



Factory configured serial interface (RS 232). With this interface in addition to date, weight & count information, two additional 15 character line entries can be included (for example Item number, operator number etc.) Printing from this interface via a single tally roll printer or label printer which will print all data in a numerical format, or in a range of standard **Barcodes**.

We reserve the right to make technical modifications and price changes without prior notification

Stainless Steel housing, IP 67



IP 67,
Tare up to 100 %
Automatic Zero
Net-/ Gross-/Tare-weighing
Simple counting
Zero setting ,
Alarm / check control setting,
back light LCD-Indicator,

OIML trade approved Class  

Diameters :

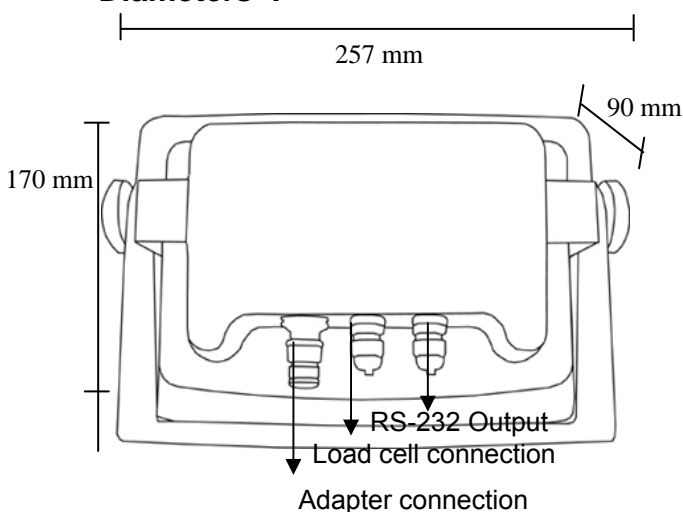

(for IP 67, for RS232 and load cells use only
cable diameter from 3 to 5,5 mm)

Technical data: Indicator: KPZ 52E-9-1 robust, stainless steel housing **IP 67**, user-friendly, large function keys. LCD display: 6 digit, various symbols, backlight, high of digits 25 mm. Operating temperature from -10°C up to $+40^{\circ}\text{C}$, operation 230 Volt through external power supply, inbuilt battery (possibility of battery operation).

Functions: automatic and manual zero setting, switch Net/Gross weight, 100% tare, multiple tare, unit switching, simple piece counting by reference no. 10, 20, 50, 100 i 200. Possibility to enter data and bring out data through serial interface (optional): computer functional control , possibility of choosing different exit formats, **printout in simple format**, edition activation : via computer, continuously or after zero come back. Minus indication, LCD backlight, automatic shut off after 0-9 minutes, pre-set value control or limit value control LOW – OK - HIGH (any two weight values to choose, tone or light signal), electronic stabilization filter and signal distortion, automatic self test, error messages.

Indication: zero setting, gross, net, stability, LOW-Bat indication, pre-set/limit value, too small piece quantity or too small weight.

LED: charging status.



Options: serial interface RS 232, battery, label printer

Key functions:

Button	Description
ON	switch the indicator ON
→0←	Switch the indicating to 0.00
OFF	switch the indicator OFF
	TARE function
NET GROSS	Switch over Net / Gross Tare, repeatedly
UNITS	Switch over weighing units
F/HR	In approval version: High resolution indication (5 sec)
M+	Totalizing and printout/ data output

We reserve the right to make technical modifications and price changes without prior notification



IP 67,
10 Setpoint memory
Tare setting by key,
Zero setting,
Alarm / check control setting,
back light LCD-Indicator,
Addition sum memory,
Multi range division,
OIML Class   10.000 e

Keypad :



Rear view and Dimension:

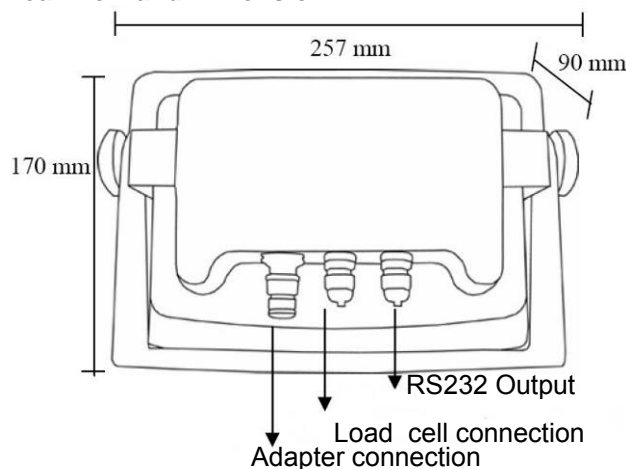

(For IP 67 use only cable diameter from 3 to 5,5mm)

Short description KPZ 51 E – 9 – 2 :

Case:

Compact, robust, high-quality stainless steel case IP 67. with hanger to the wall mounting or table mounting (optional stand possible), cable connecting by cable glands.

Indication and keyboard:

6-digit 25 mm high LCD – Display with back-light function providing a clear and easily readable weight indication, and a great, illuminated, coloured joist graphic display, a membrane keypad with 16 buttons.

Symbol indication for : zero, tare, stable, LOW Bat, accumulator tension joist , check weighing HIGH-OK-LOW.

Basic functions:

automatic and manual Zero setting. Tare setting up to 100 %, Pretare, switch Net, tare and gross weight repeatedly. Target weight check tolerance with+(/), limit value control (limit = range of Low/Ok/High), 10 debit-/ limit value lofts. About parameter attitude: Percentage function, automatic switching off of backlight and electronics, interface functions and parameter.

Feature :

Multi range, selectable weighing unit, automatic zero correction, automatic shutoff 0-9 minutes, automatic. Backlight, digital stabilization and disturbance filters, measuring speed, gravitation zones, self-test function and error messages.

Energy:

internal accumulator, power supply unit of 230 VAC.

Certifications:

EU-calibrating admittance class  to 10,000 e.

Technical date:

Max . recommended external resolution 30,000 div, min . sensitiveness 0.3 μ V/d, supply voltage 5 VDC, zero input signal-1 to 5 mV, weight input signal-1 to 14 mV up to four 350 Ω load cells, linearity 0.01% F.S.,operating temperature-10 to +40° C. **ptions:** Configurable RS 232 output, data output (different formats), Roller printer, label printer, set point (High-OK-Low),

Extended functions and optional possibilities (surcharge):

Connection:

Serial interface RS232 bidirectional, data output format and mode choice, factory programmable format, date and time, relay exit for alarm/check points.

KPZ 54-* / Touch screen indicator



- Touch Operating System for user friendly and fastest operations.
- Multi-printer selectable
- Custom printout options,
- Multi -language support
- Report management.
- PC keyboard and Mouse can be connected
- Software upgrade option.
- 9999 products possible to store in memory.
- designed for multiple use, such as Weighing, Target, Counting, Check weighing and Recipe operations.
- 2xUSB port, 1xRS232, optional more ports possible
- 7' or 8' display possible
- Robust ABS or stainless steel housing possible
- Dual scale option (extra charge) possibility



KPZ 1-*

KPZ 2- *

KPZ 2-*



KPZ 71-*

KPZ 73-*



KPZ 72-*

KPZ 74-*

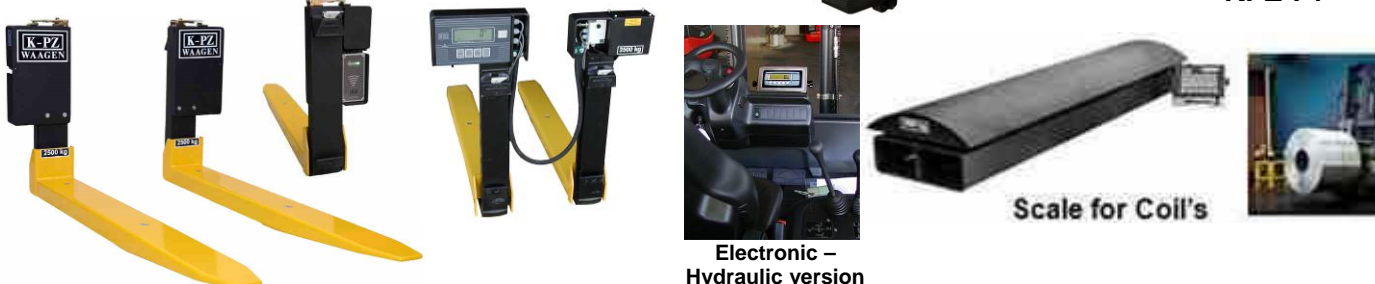

Weighing forks Forklift truck scale

Electronic – Hydraulic version

Scale for Coil's

Stainless steel, IP 67/68/ 69K



KPZ-Waagen Indicator



KPZ 52E8

KPZ 52E8-1

KPZ 56E4

KPZ 54-1*



KPZ 52-18

KPZ 52E9-1

KPZ 52E9-2